

CARBON DETERMINATIONS IN PIG IRON.

BY BERTRAND S. SUMMERS.

Received October 3, 1896.

THOSE chemists who have had occasion to do many carbon determinations in pig iron, to which was allotted but little time, have probably felt the need of improvements in some of our standard methods.

The old oxygen combustion method, although accurate, requires more time than can usually be spared if use is made of a porcelain or glass tube. However, it has the greatest of all advantages, that of accuracy. The writer has used for some time a regular Bunsen furnace with a glass tube, and while the results were all that could be desired, the time required for a refractory residue was almost three hours.

A series of experiments was conducted with the ordinary chromic acid process, but the results were quite unsatisfactory. Every precaution was taken to insure accuracy, but with high carbon residue low results were obtained in nearly every case when checked by the oxygen combustion method. This was particularly noticeable when a considerable content of graphite was present. The results checked quite well with each other and gave satisfactory results when working on steel.

As this state of affairs greatly embarrassed matters in the laboratory, an effort was made to devise some means by which the carbon could be determined with reasonable speed and accuracy.

Recognizing the advantages of the combustion method, it was decided to make use of a platinum tube. To avoid delay and expense the tube was manufactured in the factory. It was made of 0.200 stock twelve inches long and eleven-sixteenths inch in diameter. A perfectly tight tube was constructed by using ordinary gold solder, which may be obtained from any jeweler. Around each end of the tube copper coolers were brazed, in order to cool the tube in the neighborhood of the rubber stoppers. The inlet of the coolers served the double purpose of supports and water supplies. In spite of this precaution it was found that the air circulating through the heated portion of the tube was hot enough, on reaching the stoppers, to seriously affect them. In order to prevent this, the scheme shown in Fig. 3

was devised. The funnel shape protuberance here seen was filled with ignited asbestos, and the whole was removed with the stoppers. This appliance proved an effectual preventive for

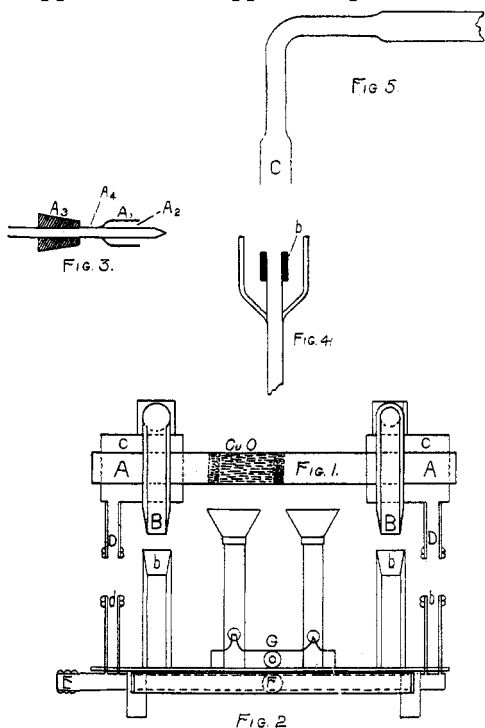

Fig. 1—*AA*, Platinum tube; *BB*, Support and water outlet; *CC*, Coolers; *DD*, Water supplies.

Fig. 2—*bb*, Sockets for *BB*; *dd*, Connection for water supply, *DD*; *E*, Main water supply; *F*, waste pipe; *G*, Gas connection.

Fig. 3—*A*₃, Stoppers; *A*₁, Glass cup for asbestos, *A*₂; *A*₀, Outlet.

Figs. 4 and 5—Showing connections for mercury joint.

avoided, the only rubber tubing in use being at the ends of the combustion tube.

The purifying train consists of a large U-tube of one and one-half inch stock and twelve inches long. The first limb is filled with broken caustic potash, and the second with fused calcium chloride. The first limb connects with a Drechsel bottle partially filled with strong sulphuric acid, and the second with the combustion tube.

further heating of the stoppers, as a red heat could be maintained two inches from them and they remain perfectly cool.

With this arrangement it was found that a high carbon residue could be burned completely in twenty minutes. It became evident from this that if the aspirating space were decreased, good results could be obtained in a comparatively short time. With this idea in view, the train depicted in the accompanying picture was designed and made by our own glass-blowers. The train has the further advantage that rubber connections are

avoided, the only rubber tubing in use being at the ends of the combustion tube.

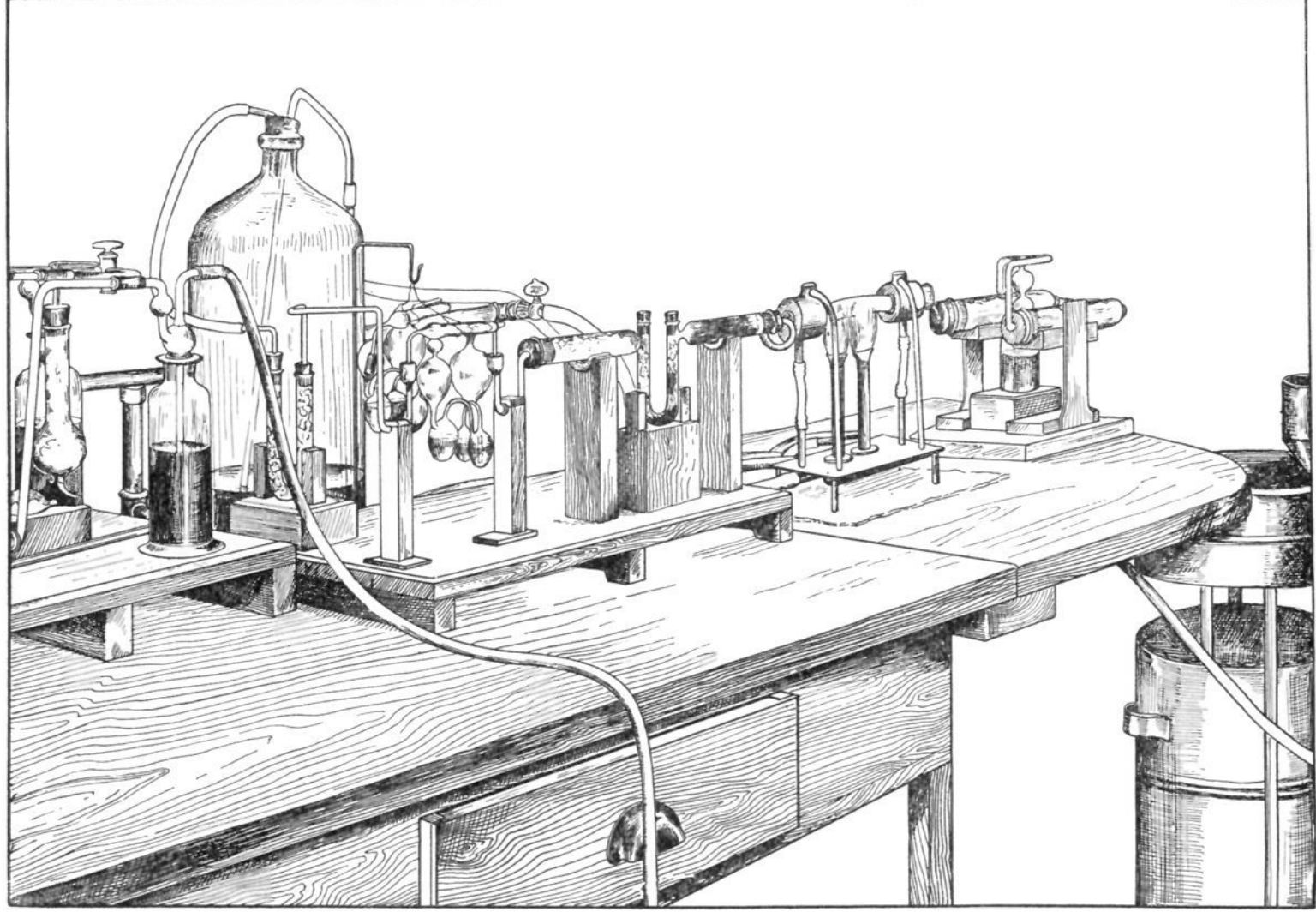

The purifying train on the absorption end is made in one piece. It consists of a five inch U-tube of thick walled glass five-eighths inch in diameter, into the sides of the limbs of which are fused arms. These arms are made of one-inch stock and about seven inches long. The first arm is filled with anhydrous cuprous chloride and anhydrous cupric sulphate. The U-tube serves as the receptacle for the sulphuric acid, and the second arm is filled with calcium chloride previously treated with an excess of carbon dioxide.

The connection with the Geissler bulbs is established by means of mercury joints. These serve to facilitate removal of the bulbs and make a joint which is perfectly secure. The joint can readily be made by any glass blower, an illustration of which is seen in Fig. 4. The end of the Geissler bulb is so reamed as to fit loosely over the tube inside the cup (Fig. 5). A small piece of rubber tubing (*b*, Fig. 4) is slipped over the tube and makes a moderately tight joint with the end of the Geissler bulb. When the cup is filled with mercury a perfect connection is obtained. The method of connecting the Geissler bulb with rubber tubing was both awkward and liable to leakage. These junctions have been in use for some time in our laboratory and have given thorough satisfaction.

With this apparatus as described the most refractory residues are burned in an hour and a half. With residues of less refractory nature and lower carbon content an estimation may be completed in less time. The blank on the apparatus never exceeds three-tenths of a milligram, and is usually one-tenth or nil.

Some results are here appended, thinking they may be of interest. Those obtained by the chromic acid process were quite scattering unless great care was exercised and sufficient time was allowed. The results from this method, given below, are those where much time was given and great pains taken to insure complete oxidation. Values from the Bunsen furnace are given to serve for comparison.

Chromic Acid Method. Total Carbon.	Bunsen Furnace. Total Carbon.
3.23	3.31
3.27	3.33
3.23	...
3.28	...

Results from the above described process, when compared with the Bunsen furnace, were very good.

Platinum Furnace. Total Carbon.	Bunsen Furnace. Total Carbon.
3.03	3.03
3.03	3.05
3.05	...

The convenience of this apparatus in expediting work in the laboratory has led me to write this description, in the hope that it might be of service to other chemists.

CHEMICAL LABORATORY, WESTERN ELECTRIC COMPANY,
CHICAGO.

NOTE ON THE SOLUBILITY OF BISMUTH SULPHIDE IN ALKALINE SULPHIDES.

By GEORGE C. STONE.

Received November 9, 1896.

IN the August number of this Journal there is a note by Prof. Stillman on this subject; he shows that if a solution containing bismuth is made alkaline by sodium hydroxide and then heated with an excess of an alkaline sulphide a considerable amount of bismuth is held in solution. On repeating his experiments qualitatively I obtained the same result, but when the bismuth was first precipitated as sulphide from an acid solution and then treated with an alkaline sulphide but little if any was dissolved.

To test the solubility quantitatively I made a solution of about one and two-tenths grams of bismuth hydroxide in 500 cc. of very dilute hydrochloric acid; in two portions, of fifty cc. each. I determined the bismuth by precipitation by ammonium carbonate, finding 0.0966 and 0.0965 gram.

I next precipitated the bismuth in two more lots of the same solution by hydrogen sulphide, filtered and heated the precipitate for half an hour with a large excess of potassium sulphide, filtered, dissolved and reprecipitated by ammonium carbonate, the bismuth weighed 0.0981 and 0.0970 gram.

Two more lots treated in the same manner, except that they were heated with ammonium sulphide, gave 0.0970 and 0.0976 gram of bismuth.

From the above it seems fair to conclude that bismuth sulphide precipitated from an acid solution is not dissolved by subsequent treatment with an alkaline sulphide.